

# 4

## THERMO-DISC VARIABLE GEOMETRY VAV CEILING DIFFUSERS

### APPLICATIONS

VAV COOLING

VAV COOLING & HEATING

### ADVANTAGES

INDIVIDUAL CONTROL

REVERSING CHANGE-OVER OPTION

HEATING/COOLING OFFSET ADJUSTMENT  
OPTION

EASY INSTALLATION-NO EXTERNAL POWER

COMMISSIONING MADE EASY

ACCURATE CONTROL

NO REGULAR MAINTENANCE

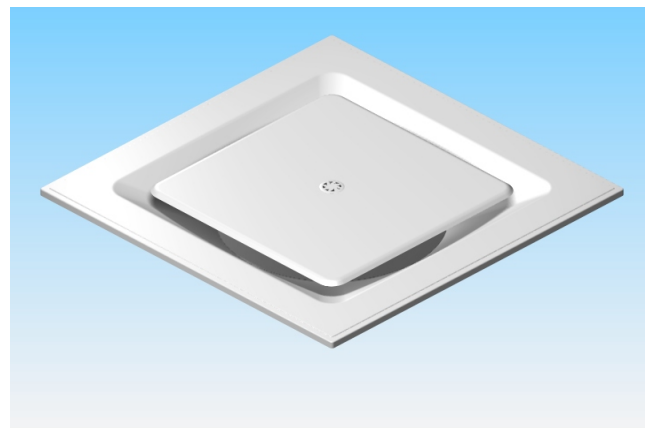

VSD

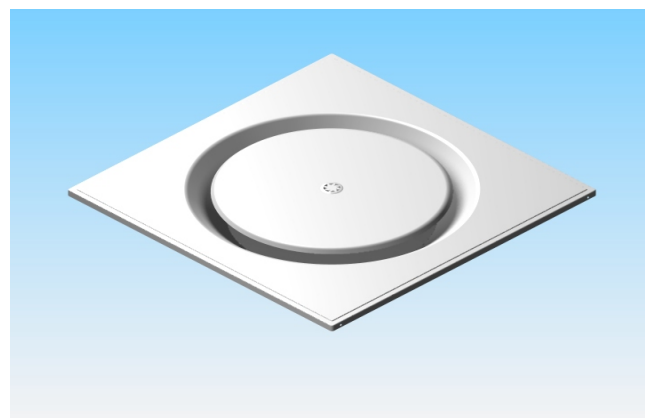

VCD



VRD

## INTRODUCTION

The RICKARD VARIABLE GEOMETRY THERMO-DISC Ceiling Diffuser is a thermally powered VAV diffuser which contains an inbuilt temperature sensing & volume control mechanism. In appearance the construction of the THERMO-DISC is identical to the popular electronically controlled Vari-Disc range of diffusers, but has the advantage that it requires no external wiring or power supply. The Thermo-Disc is available in two basic options—the Series 5 is a cooling only VAV diffuser while the Series 4 will provide full VAV control in both cooling & heating modes. Change-over between cooling & heating control modes is automatic & is carried out by means of our unique PATENTED thermal mechanism.

Supply air is discharged horizontally in UNIFORM 360° radial pattern while the Variable Geometry feature ensures that adequate room air movement is maintained throughout the full range of volume variation.

All diffusers are manufactured from sheet steel & finished in a chip resistant epoxy powder coating available in a wide range of colours.

## OPERATION

### GENERAL DISCRIPTION

Room temperature is controlled by varying the supply air in accordance with demand. No other system is more energy efficient since the volume is controlled to match exactly the requirements of the space served by the diffuser.

Volume control is achieved by moving the disc, know as the control disc, vertically up & down within the diffuser so as to vary the aperture through which the air passes. This results in the “Variable Geometry” concept which effectively maintains constant air movement throughout the range of control from 100% to down to as little as 25%.

The position of the control disc is varied by means of a wax filled thermal element which responds to changes in sensed room temperature. The wax contained in the thermal element melts at the formulated temperature to expand or contract. With a rise in sensed temperature the expanding wax extends the plunger, causing the amplifying lever-arm mechanism to move the control disc such that the supply air volume is changed to the extent that is required to maintain constant Room temperature. When the wax cools down the plunger retracts under the action of the return spring, causing the control disc to move in the opposite direction to counter the change in sensed temperature.

The room temperature sensing element is located behind the induction cap in the diffuser appearance panel, known as the trim plate. This is the ideal position to sense room temperature owing to the high rate of induced room air across the trim-plate.

Adjustment of the room temperature setpoint is achieved by rotating the blue adjustment ring as indicated below. To access this ring, rotate the diffuser trim-plate counter clockwise & remove the entire trim-plate/mechanism assembly. The adjustment ring has calibrated temperature markings to suit

individual occupant requirements. It is advisable that no change be made to the factory 22°C factory setting until the space is occupied. This will provide for realistic operating conditions, after which individual diffusers may be adjusted to suit each individual occupant.

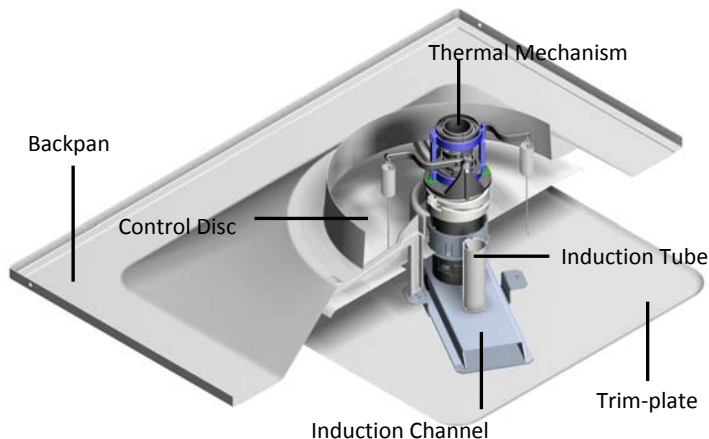

### COOLING/HEATING THERMO-DISC

The Series 4 Cooling/Heating Thermo-Disc Diffuser is identical in appearance to the cooling only version, the only difference being the addition of a second thermal element within the mechanism which automatically changes the action of the diffuser when the system goes into the heating mode. This allows full VAV control of the room when warm air is being supplied to the diffuser.

The cooling/heating change over thermal element is similar to that used for sensing room temperature allowing heating change over to be initiated when the supply air temperature is elevated to 24°C and is completed when the supply air temperature reaches 29°C. Under these circumstances the diffuser will open as sensed room temperature decreases & vice verse. Change over back to the cooling mode will be completed when the supply air temperature is decreased to 22°C. For best results the supply air temperature must be maintained above or below the change over range.

For a full description of VAV systems and system design, kindly refer to section 1 of this catalogue

### THERMAL MECHANISM

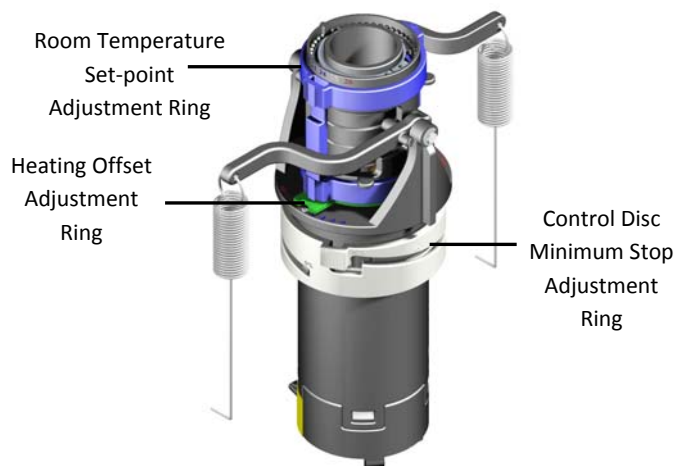

## THERMO-DISC VARIABLE GEOMETRY DIFFUSER PERFORMANCE

VCD VSD VRD

SIZE	READING	NECK TOTAL PRESSURE (Pa)								
		20	30	40	50	60	70	80	90	100
150	FLOW l/s	63	77	88	99	108	117	125	133	140
	THROW m	2.0	2.1	2.7	3.0	3.3	3.5	3.7	4.0	4.2
	NC LEVEL	-	-	-	-	26	28	31	33	35
200	FLOW l/s	96	118	137	153	169	184	195	207	218
	THROW m	2.0	2.6	3.0	3.2	3.6	3.9	4.2	4.5	4.7
	NC LEVEL	-	27	28	29	30	33	36	38	40
250	FLOW l/s	140	171	198	221	242	261	279	296	313
	THROW m	2.4	2.6	3.2	3.5	3.9	4.2	4.5	4.7	5.1
	NC LEVEL	-	27	29	31	33	36	38	40	42
300	FLOW l/s	176	216	250	280	307	332	355	377	398
	THROW m	2.5	2.8	3.3	3.7	4.2	4.6	4.8	5.2	5.4
	NC LEVEL	27	28	30	32	35	37	39	4.1	43

Throw data is taken 25mm below the ceiling on a line through the centre of the diffuser with the control disc fully open & an air velocity at 0.25m/s. Noise criteria levels apply to a single diffuser mounted in a room having a Sound Absorption of 10dB in octave bands having centre frequencies from 125Hz to 8000Hz (i.e. the difference between Sound Pressure Level (dB re:  $2 \times 10^{-5}$  Pa) and Sound Pressure Level (dB re:  $10^{-12}$ ) is equal to 10dB). These levels represent only the noise generated by the diffuser and do not take into account any duct-borne noise.

Diffusers are factory set for a minimum of 30% of the maximum flow levels reflected above. It should be noted that minimum diffuser air flow settings are approximate & may require to be reset on site to compensate for actual site system pressures.

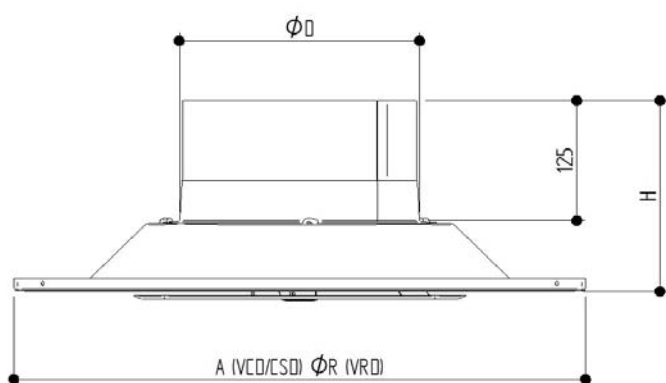

NOMINAL SIZE	DIMENSIONS (mm)			
	Ø D	A	H	Ø R
150	153	495 x 495 595 x 595	204	580
200	200	495 x 495 595 x 595	201	580
250	250	495 x 495 595 x 595	196	580
300	293	495 x 495 595 x 595	195	580

## ADVANTAGES OF THE THERMO-DISC

### PERSONALIZED COMFORT

THERMO-DISC diffusers control their own VAV zones, with each diffuser adjusted individually between temperatures of 20°C and 24°C. The THERMO-DISC mechanism will sense and control temperature within 1.5°C of set temperature (factory setting 22°C). There is no need for wall mounted thermostats which are often situated incorrectly ie. in incorrect rooms or on walls effected by external load sources. As the THERMO-DISC room temperature sensing element is located on the diffuser face and is equipped with high efficiency induction inducers, average room temperature is accurately sensed.

### CAPITAL & OPERATING COST SAVINGS

The THERMO-DISC is a self powered Variable Geometry VAV diffuser which requires no outside power source - neither electrical nor pneumatic. The numerous savings are immediately obvious, no wall thermostats or any other electro-mechanical equipment is required.

### LOW MAINTENANCE

The Rickard THERMO-DISC requires no routine maintenance and is reliable having undergone laboratory life cycle testing that exceed an expected 20 years of operation. The absence of electrical or pneumatic equipment & accessories also results in less maintenance and fewer potential problems. All moving components are easily accessible from below the ceiling. The only items ever likely to require attention are the thermal elements, which may be easily replaced. Rickard offers a 3 year manufacturers warranty on the thermal element itself.

### FLEXIBILITY

The THERMO-DISC can be relocated with ease, there is no need to move electrical cables or pneumatic tubes or other related equipment. If additional diffusers are required, these may be fitted with minimal disruption to the overall air conditioning system.

### GREEN BUILDING COMPLIANCE & ENERGY EFFICIENCY

The Rickard "PATENTED THERMO-DISC" Variable Geometry VAV diffuser mechanism is the only unit internationally available to incorporate a single room temperature adjustment facility and also incorporates heating OFFSET adjustment. For example, each diffuser is factory set to control room temperature at 22°C and zero °C heating OFFSET, meaning that the unit will control at 22°C in both heating and cooling modes. However should the engineer/property owner elect to further optimize the Variable Geometry VAV system energy efficiency, the heating OFFSET could be set, either in at the factory or on site, to minus 2°C, meaning that the THERMO-DISC diffuser will control room temperature at 22°C in the cooling mode and 20°C in the heating mode. The single room setpoint adjustment facility allows for either factory or site temperature adjustment in the range 20°C to 24°C and heating OFFSET adjustment at anything in the range from minus 2°C to plus 2°C. If, therefore, energy efficiency is to be sacrificed in favour of comfort, room setpoint temperature could be set at 20°C in the cooling mode (summer) with heating OFFSET adjusted to plus 2°C resulting in a 22°C heating (winter) mode setpoint

temperature. In addition, it must be noted that should the single setpoint adjuster be used to select a revised setting, the heating OFFSET will remain unchanged unless purposely readjusted.

## TEN YEAR WARRANTY

Rickard warrants that the THERMO-DISC diffusers, exclusive of any options or accessories (whether factory or field installed) shall be free from defects of material or workmanship for a period of ten (10) years from date of shipment and agrees to repair or replace, at its option, any parts that fail during said period due to any such defects which would not have occurred had reasonable care been taken, provided such parts have been inspected by Rickard and found defective and provided the diffusers have been given normal and proper usage and all parts and controls remain unaltered.

Rickard makes no warranty or merchantability of products or of their fitness for any purpose or any other express or implied warranty which extends beyond the limited warranty above. Rickard's liability for any and all losses and damage resulting from defects shall in no event exceed the cost of repair or replacement of parts found defective upon examination by Rickard. In no event shall Rickard be liable for incidental, indirect or consequential damages or damages or injury to persons or property. Rickard shall not be responsible for freight to or from its premises in connection with the inspection, repair or replacement or parts under the terms of this limited warranty for the cost of removal or installation.

**DIFFUSER DIRECTIONAL BLOW OPTIONS**

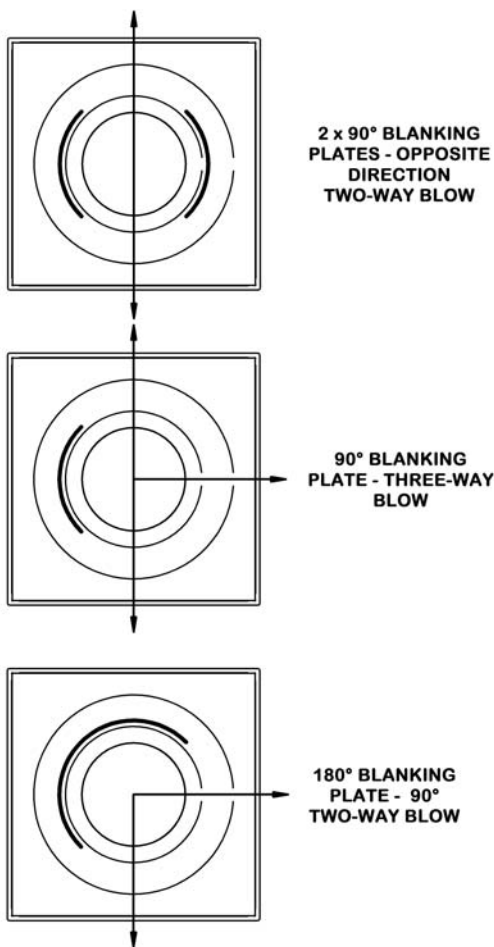

Supply air directional blanking for RICKARD VCD, VSD & VRD ceiling diffusers is achieved with the use of simple blanking plates. These blanking plates are fixed to the diffuser trim plate and are available in 90° and 180° curved form for the various neck sizes.

Please note that throw data presented in the catalogue will no longer be valid when blanking plates are installed. The catalogued data is for 360° blow only.

**GENERAL**

**ADDITIONAL THERMO-DISC INFORMATION**

The first consideration when designing a system is to calculate the required air volume and temperature to satisfy room conditions at maximum heat loads. It is essential that ducting is sized using the static-regain method. Velocities in branch ducts should be in the range 3,5 - 7.5m/s. Thereafter the following should be considered:

**THROW**

This is the distance from the diffuser at which the air velocity has reduced to 0,25 m/s when measured 25mm below the ceiling (or from the wall) with the diffuser in the fully open position. To avoid "coning" which occurs when two air streams travelling in opposite directions meet and result in a downward moving cone of air, diffusers should be spaced such that the distance between two diffusers is slightly less than the sum of their throws.

**NOISE LEVEL REQUIREMENTS**

This must be checked to ensure compliance with project specifications. The NC levels given in Table 1 are taken at a distance of 2m from the diffuser in a normal office environment. These represent only the noise regenerated by the diffuser and do not take into account any duct-borne noise. (To obtain approximate dBA readings, add 5 dB to the NC levels.)

**DUCT STATIC PRESSURE**

Diffuser performance has been established using diffuser neck TOTAL pressure, although what is normally known and controlled is duct STATIC pressure. What happens between the duct and the diffuser depends on the length and type of flexible duct.

Although the catalogue gives diffuser performance for neck total pressures ranging from 20 to 100 Pa, caution should be exercised when selecting diffusers outside the range of 40 to 80 Pa. At lower pressures air movement and induction may be insufficient and at higher pressures draughts and excessive noise may result. Best results are obtained when diffusers are selected at pressures of 50 to 70 Pa. Bear in mind that all diffusers on a particular branch will operate at the same static pressure, as controlled by the pressure control damper. Diffusers that are able to supply more air than required will be driven partially closed by the thermal element and therefore the system becomes self-balancing.

NOTE: Avoid placing restrictions (such as manually operated dampers or squashed flexible ducts) at any point in branch ducts. The reason for this being that at maximum flow these restrictions result in a significant static pressure loss but at minimum flow conditions offer virtually no resistance, which will result in the static pressure at the diffuser being too high, with predictable results.

Throw data is taken 25 mm (1") below the ceiling, on a line through the centre of the diffuser with the diffuser control disc fully open. Air velocity is 0.25 m/s (50 fpm). Noise Criteria ratings are taken for a standard office environment 2 m (6') from the diffuser. Diffusers are factory set for an approximate minimum air quantity of 33% of the maximum levels reflected above. It should be noted that the minimum air settings are only approximate and may require to be reset on site to compensate for the actual site system pressures.

**Total Pressure can be calculated as follows:**

$P_{total} = P_{static} + P_{velocity}$

$P_{velocity} = constant * (volume/1000)^2$

NECK SIZE	CONSTANT
150	1921.350
200	607.927
250	249.007
300	120.084



### VRD THREE-POINT FIXING CLIPS

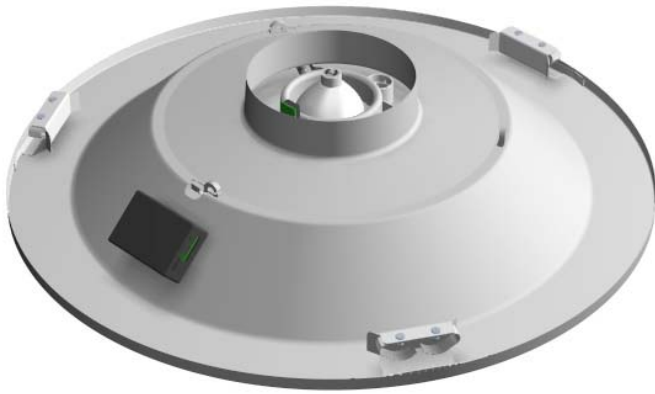

### CEILING CUT-OUT DETAIL FOR ROUND DIFFUSERS

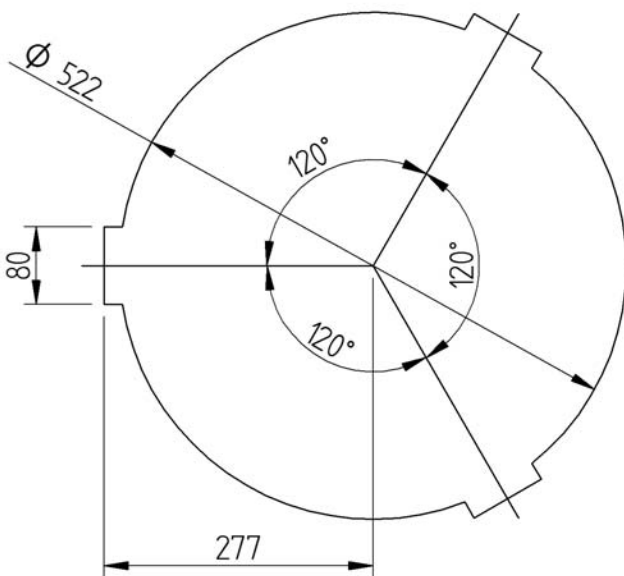

### COMMISSIONING THE THERMO-DISC

As is the case with all the RICKARD VARIABLE GEOMETRY VAV equipment, the Thermo-Disc is simple to commission. However, there are some fundamental steps and precautions that are required in this process.

If not at sea level, make sure the necessary altitude corrections have been applied. In order to standardize, all pressures quoted in this manual have been rated at sea level and 20°C. Therefore if, for example, the site is at an altitude of 900m above sea level and the supply air temperature 15°C, the catalogue pressure required to satisfy a design air volume must be multiplied by a relative density factor of 0.90.

After having corrected the performance figures for the site conditions, either of the following methods may be used to commission the system and to ensure that the design air quantities are obtained. The first method requires a pitot tube and manometer to measure pressure while the second method requires a diffuser balancing hood or cone to measure volume.

### METHOD 1

In the branch duct under consideration, open all the diffuser control discs to the maximum air position. This is achieved by unclipping the control disc suspension springs from the control disk. Now select the diffuser requiring the highest pressure (index diffuser) and carefully measure the total pressure in the inlet spigot or neck of the diffuser. If this criterion does not correspond with that given in the selection data (corrected for altitude if necessary), re-adjust the static pressure in this branch duct until the desired total pressure in the diffuser neck has been achieved. If the index diffuser was correctly selected, the remainder of the diffusers served by this branch duct should all be achieving at least the design air volume. A few spot checks may be carried out on other diffusers if required. The diffuser control discs should be re-attached and the same procedure followed for all other branch ducts.

### METHOD 2

For the second method of commissioning, all the diffusers served by the branch duct under consideration must again be unclipped to the fully open position. Identify the index diffuser as before and carefully measure its air volume by using the correct sized balancing hood. Adjust the static pressure in the branch duct until this diffusers desired air volume has been achieved. After this the remainder of the diffusers on this branch duct should be delivering at least the design air quantity and a few spot checks may be carried out.

Note that some diffusers may be delivering more than the design air quantity. This is not a problem because if any room receives too much air, it will result in the room temperature drifting away from set point and the diffuser will in turn close to the point where the room temperature is achieved. The system is therefore self-balancing. Do not attempt to reduce the maximum air quantity by means of a flow restricting device such as a manual balancing damper.

Avoid commissioning a system when warm air is being supplied by the air handling unit, especially when the balancing hood method is used to measure air volumes. The "stack effect" created by the hood artificially reduces the volume of air through that diffuser.

For the commissioning of larger and more complex systems please contact your nearest Rickard Air Diffusion representative.

## SAMPLE THERMO-DISC SPECIFICATION

### COOLING/HEATING TYPE 4:

Supply and install Rickard type 4 VCD/VSD/VRD Variable Geometry Thermo-Disc VAV Diffusers, incorporating automatic cooling/heating change-over, where indicated on the project drawings. The diffusers shall have a single room temperature setpoint adjustment facility with dependent heating offset adjustment such that full VAV heating will take place at a setpoint either at a lower or higher level than cooling setpoint, to suit the building occupants. For maximum efficiency and GREEN Building considerations, heating offset should be adjusted such that VAV cooling takes place at a setpoint of 2°C higher than VAV heating.

The diffusers shall provide full VAV control of supply air in both cooling and heating modes. The diffusers shall remain in the cooling mode until the temperature of supply air exceeds 24°C after which the change over sensor shall place the diffuser into the heating mode where it will remain until the supply air temperature is reduced to a level of below 22°C. All control components, including the thermal mechanism, shall be removable from below the ceiling without the use of any tools by merely rotating the trim plate in a counter clockwise direction through no more than 5°.

Control of supply air shall be by means of a single aluminium vertically moving Control Disc designed, in conjunction with the diffuser backpan, to interactively provide perfect ceiling Coanda and excellent room air induction to ensure no stratification or dumping takes place throughout the cooling and heating control range. Room temperature shall be sensed through a centrally mounted trim plate induction port. To ensure that the best possible room air entrainment over the thermal sensing element takes place, an efficient induction channel and induction venturi tube shall be part of the diffuser design

### COOLING ONLY TYPE 5:

Supply and install Rickard type 5 VCD/VSD/VRD Cooling only Variable Geometry Thermo-Disc VAV Diffusers where indicated on the project drawings. All control components, including the thermal mechanism, shall be removable from below the ceiling without the use of any tools by merely rotating the trim plate in a counter clockwise direction through no more than 5°.

Control of supply air shall be by means of a single aluminium vertical moving Control Disc designed, in conjunction with the diffuser backpan, to interactively provide perfect ceiling Coanda and excellent room air induction to ensure no dumping takes place throughout the cooling control range. Room temperature shall be sensed through a centrally mounted trim plate induction port. To ensure that the best possible room air entrainment over the thermal sensing element takes place an efficient induction channel and induction venturi tube shall be part of the diffuser design.